



Count on it.

Operator's Manual

21-inch Walk-Behind Aerator

Model No. 23515—Serial No. 31200001 and Up

Model No. 33515—Serial No. 31200001 and Up

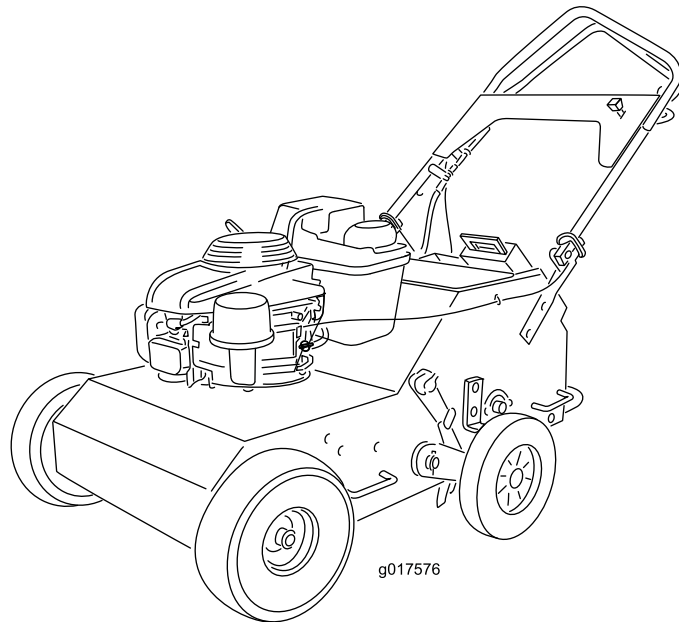

WARNING

CALIFORNIA Proposition 65 Warning

The engine exhaust from this product contains chemicals known to the State of California to cause cancer, birth defects, or other reproductive harm.

This spark ignition system complies with Canadian ICES-002.

Important: This engine is not equipped with a spark arrester muffler. It is a violation of California Public Resource Code Section 4442 to use or operate the engine on any forest-covered, brush-covered, or grass-covered land. Other states or federal areas may have similar laws.

Introduction

This aerator, which is controlled by a walking operator, is intended to be used by trained operators in residential and commercial applications. It is primarily designed for aerating small to mid-sized areas of well-maintained lawns on residential grounds, parks, sports fields, and on commercial grounds.

Read this information carefully to learn how to operate and maintain your product properly and to avoid injury and product damage. You are responsible for operating the product properly and safely.

You may contact Toro directly at www.Toro.com for product and accessory information, help finding a dealer, or to register your product.

Whenever you need service, genuine Toro parts, or additional information, contact an Authorized Service Dealer or Toro Customer Service and have the model and serial numbers of your product ready. Figure 1 illustrates the location of the model and serial numbers on the product. Write the numbers in the space provided.

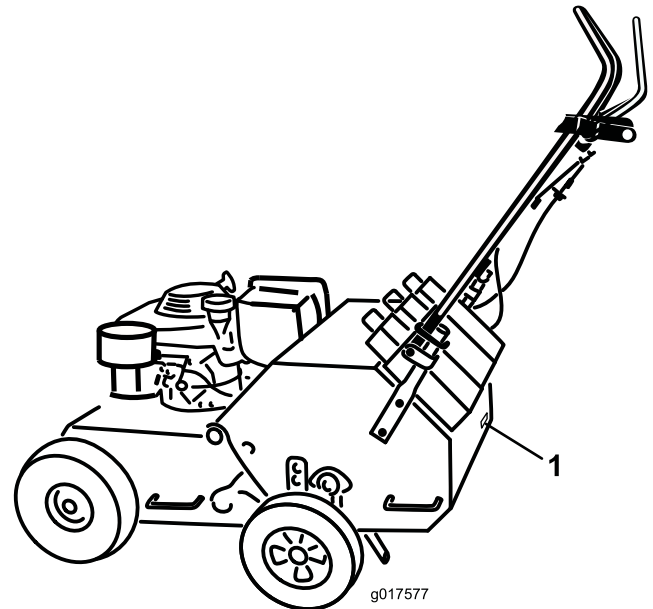

Figure 1

1. Location of the model and serial numbers

Model No. _____

Serial No. _____

This manual identifies potential hazards and has safety messages identified by the safety alert symbol (Figure 2), which signals a hazard that may cause serious injury or death if you do not follow the recommended precautions.



Figure 2

1. Safety alert symbol

This manual uses 2 other words to highlight information. **Important** calls attention to special mechanical information and **Note** emphasizes general information worthy of special attention.

Contents

Introduction	2
Safety	3
Safe Operating Practices	3
Slope Indicator	5
Safety and Instructional Decals	6
Setup	7
Unfolding the Handle	7
Checking the Oil Level	7
Product Overview	7
Controls	7
Specifications	8
Attachments/Accessories	8
Operation	8
Checking the Engine Oil Level	8
Filling the Fuel Tank with Gasoline	9
Starting the Engine	9
Stopping the Engine	10
Driving the Machine	10
Aerating	11
Adding Weight	11
Adjusting the Coring Depth	11
Securing the Machine for Transport	12
Operating Tips	12
Maintenance	13
Recommended Maintenance Schedule(s)	13
Pre-maintenance Procedures	13
Accessing the Tines	13
Tipping the Machine	14
Lubrication	15
Greasing the Center Tines	15
Lubricating the Drive Chains	15
Engine Maintenance	16
Servicing the Air Cleaner	16
Changing the Engine Oil	16
Changing the Oil Filter	17
Servicing the Spark Plug	17
Fuel System Maintenance	18
Replacing the Fuel Filter	18
Drive System Maintenance	19
Checking the Tire Pressure	19
Checking the Tension of Aerator Drive Chains	19
Belt Maintenance	20
Checking the Hydrostatic Drive Belt	20
Controls System Maintenance	20
Adjusting the Machine Ground Speed	20
Tine Maintenance	21
Checking/Replacing Tines	21
Storage	22
Troubleshooting	23

Safety

Improper use or maintenance by the operator or owner can result in injury. To reduce the potential for injury, comply with these safety instructions and always pay attention to the safety alert symbol, which means *Caution, Warning, or Danger*—personal safety instruction. Failure to comply with the instruction may result in personal injury or death.

Safe Operating Practices

The following instructions are adapted from the ANSI B71.4—2004 and B71.8—2004 standard.

Training

- Read the *Operator's Manual* and other training material. If the operator(s) or mechanic(s) can not read English it is the owner's responsibility to explain this material to them.
- Become familiar with the safe operation of the equipment, operator controls, and safety signs.
- All operators and mechanics should be trained. The owner is responsible for training the users.
- Never let children or untrained people operate or service the equipment. Local regulations may restrict the age of the operator.
- The owner/user can prevent and is responsible for accidents or injuries occurring to himself or herself, other people or property.

Preparation

- Evaluate the terrain to determine what accessories and attachments are needed to properly and safely perform the job. Only use accessories and attachments approved by the manufacturer.
- Wear appropriate clothing including safety glasses and hearing protection. Long hair, loose clothing, or jewelry may get tangled in moving parts.
- Inspect the area where the equipment is to be used and remove all objects such as rocks, toys, and wire which can be contacted by the aerator.
- Use extra care when handling gasoline and other fuels. They are flammable and vapors are explosive.
 - Use only an approved container.
 - Never remove the gas cap or add fuel with the engine running.
 - Allow the engine to cool before refueling.
 - Do not smoke.
 - Never refuel or drain the aerator indoors.
- Check that the controls, safety switches, and shields are attached and functioning properly. Do not operate unless they are functioning properly.

Operation

- Never run an engine in an enclosed area.
- Only operate in good light, keeping away from holes and hidden hazards.
- Be sure all drives are in neutral before starting engine.
- Never operate without the shields, covers, or other guards securely in place. Be sure all interlocks are functioning properly.
- Do not change the engine governor setting or overspeed the engine.
- Raise the tines, stop the machine, and stop the engine before leaving the operator's position for any reason.
- Stop the equipment and inspect the tines after striking an object or if an abnormal vibration occurs. Make necessary repairs before resuming operation.
- Keep hands and feet away from the tine area.
- Never carry passengers and keep pets and bystanders away.
- Be alert, slow down, and use caution when making turns. Look behind and to the side before changing directions.
- Slow down and use caution when crossing roads and sidewalks.
- Do not operate the aerator under the influence of alcohol or drugs.
- Lightning can cause severe injury or death. If lightning is seen or thunder is heard in the area, do not operate the machine; seek shelter.
- Use extreme care when loading or unloading the aerator into a trailer or truck.
- Use care when approaching blind corners, shrubs, trees, or other objects that may obscure vision.
- Always be aware of obstacles that may be in the area of operation. Plan your aeration path to avoid contact with any obstacle by you or the machine.
- Let the engine cool before storing and do not store near flame.
- Shut off the fuel while storing or transporting on trailers. Do not store fuel near flames or drain indoors.
- Park the aerator on level, hard ground. Never allow untrained personnel to service it.
- Use jack stands or safety latches to support the machine when working under it.
- Remove the spark plug wire before making any repairs.
- Keep hands and feet away from moving parts. If possible, do not make adjustments with the engine running.
- Keep all parts in good working condition and all hardware tightened. Replace all worn or damaged decals.
- Use only Toro-approved attachments. The warranty may be voided if the machine is used with unapproved attachments.

Slope Operation

- Do not operate on slopes when grass is wet. Slippery conditions reduce traction and could cause sliding and loss of control.
- Do not make sudden turns or rapid speed changes.
- Reduce speed and use extreme caution on slopes.
- Remove or mark obstacles such as rocks, tree limbs, etc. from the operating area. Tall grass can hide obstacles.

Maintenance and Storage

- Wait for all movement to stop before adjusting, cleaning, or repairing. Raise the tines, stop the machine, stop the engine, and disconnect the spark plug wire.
- Clean grass and debris from the tines, drives, mufflers, and engine to help prevent fires. Clean up oil or fuel spillage.

Slope Indicator

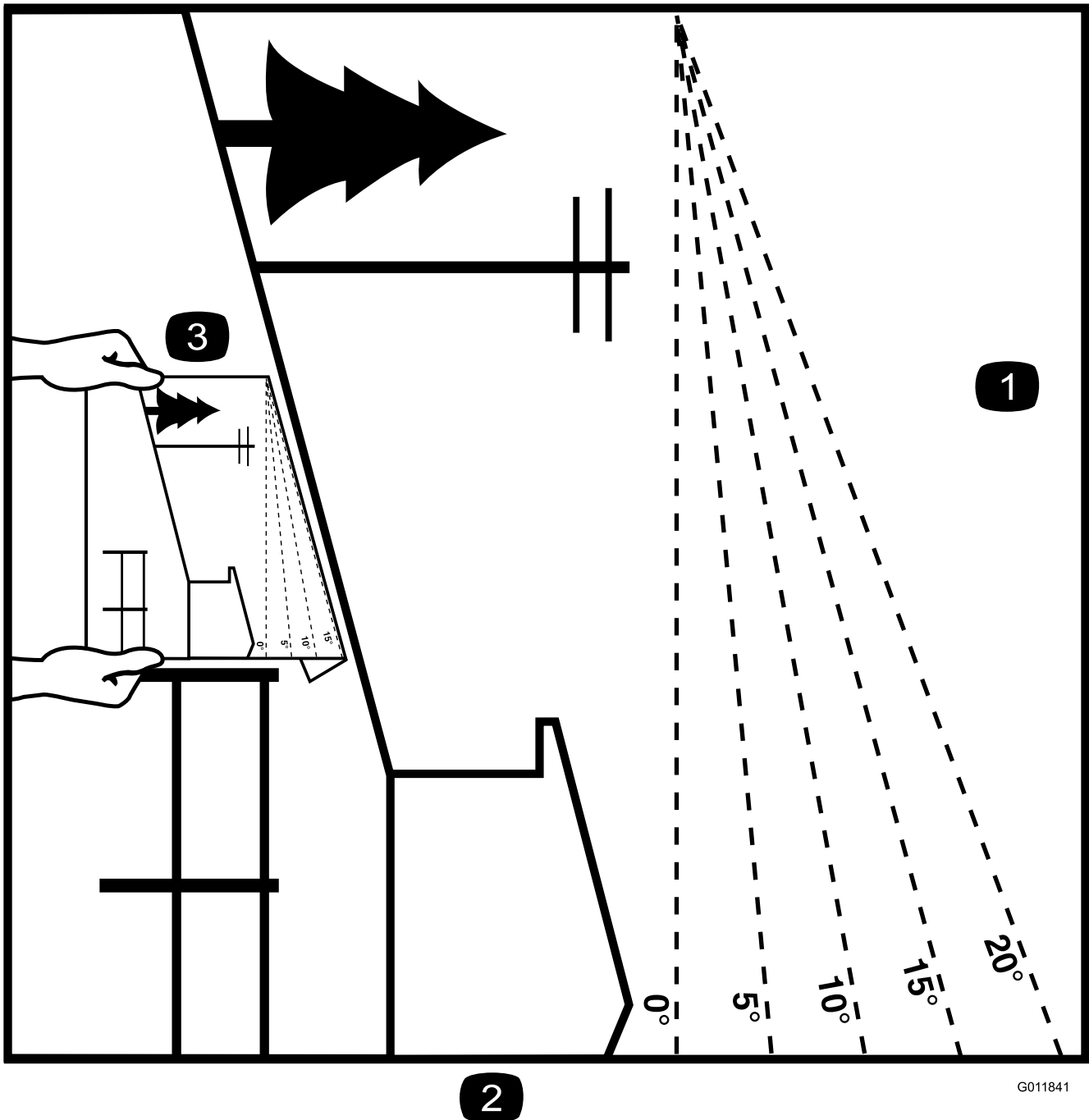

2

G011841

Figure 3

This page may be copied for personal use.

1. The maximum slope you can safely operate the machine on is **20 degrees**. Use the slope chart to determine the degree of slope of hills before operating. **Do not operate this machine on a slope greater than 20 degrees**. Fold along the appropriate line to match the recommended slope.
2. Align this edge with a vertical surface, a tree, building, fence pole, etc.
3. Example of how to compare slope with folded edge.

Safety and Instructional Decals



Safety decals and instructions are easily visible to the operator and are located near any area of potential danger. Replace any decal that is damaged or lost.

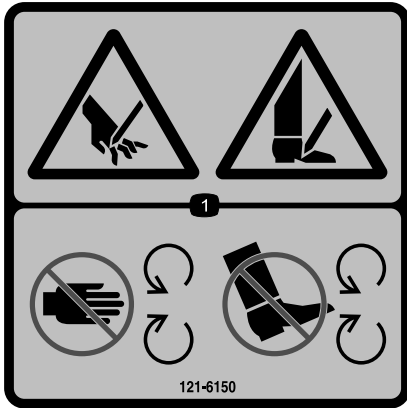

121-6150

1. Cutting hazard of hand and foot—stay away from moving parts.



119-0217

1. Warning—stop the engine; stay away from moving parts; keep all guards and shields in place.

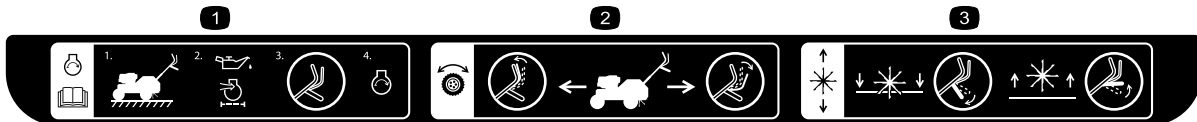

121-2008

1. To start the engine, read the *Operator's Manual* —(1) Park the machine on a level surface (2) Fill the engine with oil (3) Move the control bars to a neutral position (4) Start the engine.
2. Traction drive—move the traction control lever forward to move the machine forward; move the traction control lever backward to move the machine backward.
3. Raising/Lowering the tines—push the control lever down to lower the tines; pull the control lever up to raise the tines.

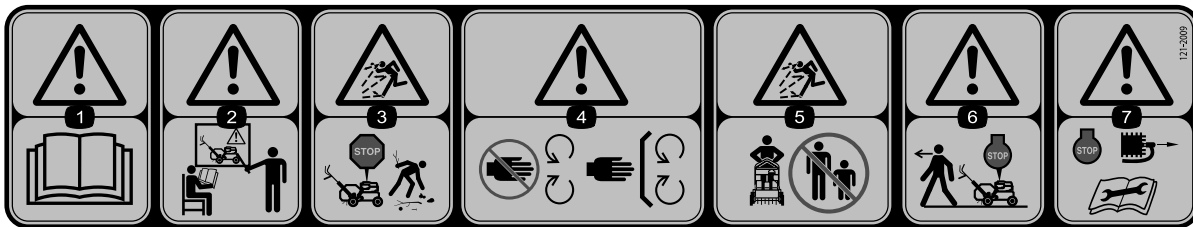

121-2009

1. Warning—read the *Operator's Manual*.
2. Warning—do not operate this machine unless you are trained.
3. Thrown object hazard—stop the machine and pick up debris before operating.
4. Warning—keep hands away from moving parts, keep all guards and shields in place.
5. Thrown object hazard—keep bystanders a safe distance from the machine.
6. Warning—stop the engine before leaving the machine.
7. Warning—stop the engine and remove the spark plug wire before performing any maintenance on the machine.

Setup

Unfolding the Handle

1. Raise the handle to the operating position.

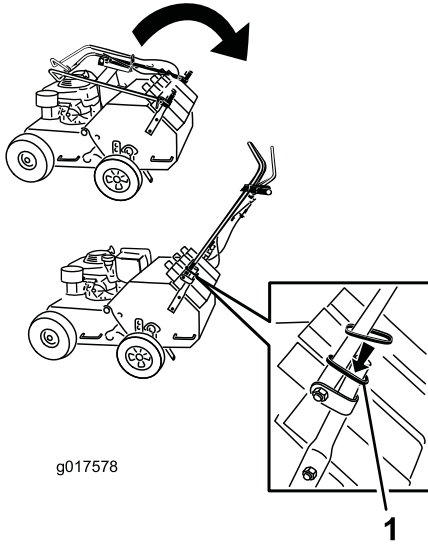

Figure 4

2. Slide the oval locking rings down each side of the upper handle over the lower handle, locking the handle sections together.

Checking the Oil Level

Before operating, check the engine oil level to ensure that it has enough oil. Refer to Checking the Engine Oil Level in Checking the Engine Oil Level (page 8), for oil specifications and instructions.

Product Overview

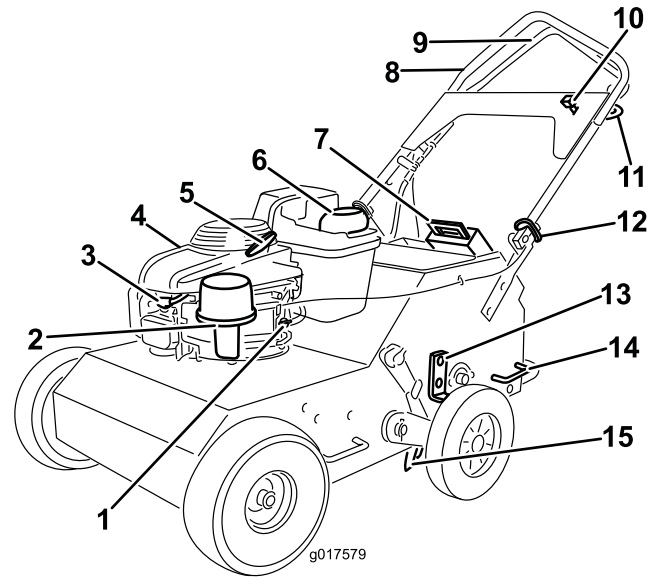

Figure 5

- | | |
|------------------------|------------------------------|
| 1. Fuel shut-off valve | 9. Traction control lever |
| 2. Air cleaner | 10. Throttle lever |
| 3. Spark plug wire | 11. Tine control lever |
| 4. Engine | 12. Oval handle locking ring |
| 5. Recoil starter | 13. Coring depth, wheel stop |
| 6. Fuel tank | 14. Tie-down/lift loops |
| 7. Rear weights | 15. Tines |
| 8. Handle | |

Controls

Recoil Starter

Pull the recoil starter handle to start engine (Figure 5).

Fuel Shut-off Valve

Close the fuel shut-off valve when transporting or storing the machine (Figure 5).

Throttle Lever

Before starting a cold engine, move the throttle lever forward to the Choke position. After the engine starts, pull the throttle lever back to the Fast position.

Note: A warm engine requires little or no choking.

Traction Control Lever

The traction control lever controls the forward, reverse, and neutral actions of the machine. Refer to Driving the Machine (page 10) for more information.

Tine Control Lever

The tine control lever lifts the rear wheels, causing the rear of the machine to be supported on the aerating tines. Push the tine control lever down to lift the wheels and drop the tines. Pull it up to lower the wheels and raise the tines out of the ground.

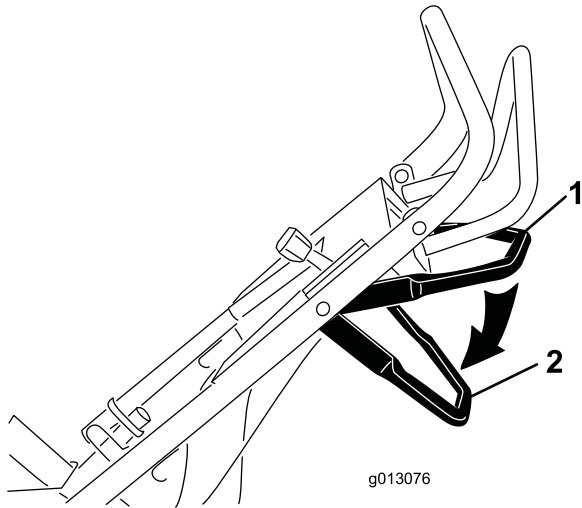

Figure 6

1. Tine control lever—raised position
2. Tine control lever—lowered position

Specifications

Length (operating)	61 inches (155 cm)
Length (with handle stored)	48.5 inches (123 cm)
Width	31 inches (79 cm)
Height (operating)	45.25 inches (115 cm)
Height (with handle stored)	32.5 inches (82.5 cm)
Weight (as shipped with 1 weight)	310 lb (140.6 kg)

Attachments/Accessories

A selection of Toro approved attachments and accessories are available for use with the machine to enhance and expand its capabilities. Contact your Authorized Service Dealer or Distributor or go to www.Toro.com for a list of all approved attachments and accessories.

Operation

Note: Determine the left and right sides of the machine from the normal operating position.

Checking the Engine Oil Level

Service Interval: Before each use or daily

The engine crankcase can hold 20 ounces (0.55 liters) of oil. Use only high-quality SAE 10W-30 weight detergent oil that has the American Petroleum Institute (API) service classification SH, SJ, SI or higher.

Note: When the crankcase is empty, pour about 3/4 of the crankcase capacity of oil in the crankcase, then follow the procedure in this section.

1. Move the machine to a level surface.
2. Clean around the dipstick (Figure 7).

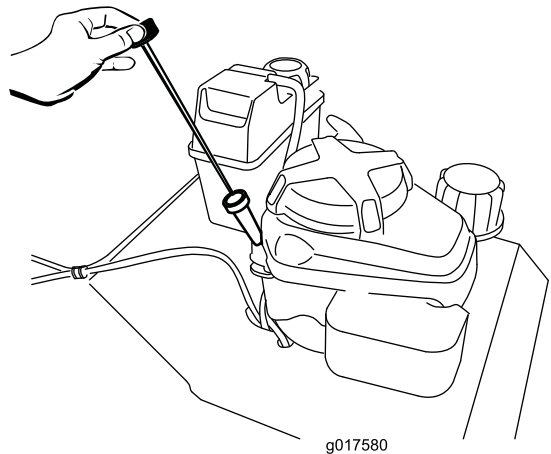

Figure 7

3. Remove the dipstick by rotating the cap counterclockwise and pulling it out.
4. Wipe the dipstick clean with a clean cloth.
5. Insert the dipstick into the filler neck, but **do not rotate the cap clockwise to secure it**, then remove it.
6. Read the oil level on the dipstick.
7. If the oil level reading is below the lower limit mark on the dipstick, remove the dipstick and **slowly** pour only enough oil into the filler hole to raise the oil level to the upper limit mark on the dipstick.
Important: Do not overfill the crankcase with oil and run the engine; engine damage will result. Drain the excess oil until the oil level reaches the upper limit mark on the dipstick.
8. Insert the dipstick into the filler neck and rotate the cap clockwise until it is tight.

Filling the Fuel Tank with Gasoline

Fuel tank capacity: 1 US Gallon (3.8 l)

▲ DANGER

In certain conditions, gasoline is extremely flammable and highly explosive. A fire or explosion from gasoline can burn you and others and can damage property.

- Fill the fuel tank outdoors, in an open area, and when the engine is cold. Wipe up any gasoline that spills.
- Do not fill the fuel tank completely full. Add gasoline to the fuel tank until the level is 1/4 to 1/2 in. (6 to 13 mm) below the bottom of the filler neck. This empty space in the tank allows the gasoline to expand.
- Never smoke when handling gasoline, and stay away from an open flame or where a spark may ignite the gasoline fumes.
- Store gasoline in an approved fuel container and keep it out of the reach of children.
- Never buy more than a 30-day supply of gasoline.

▲ DANGER

When fueling, under certain circumstances, a static charge can develop, igniting the gasoline. A fire or explosion from gasoline can burn you and others and damage property.

- Always place gasoline containers on the ground and away from your vehicle before filling.
- Do not fill gasoline containers inside a vehicle or on a truck or trailer bed because interior carpets or plastic truck bed liners may insulate the container and slow the loss of any static charge.
- When practical, remove gasoline-powered equipment from the truck or trailer and refuel the equipment with its wheels on the ground.
- If this is not possible, then refuel such equipment on a truck or trailer from a portable container, not from a gasoline dispenser nozzle.
- If you must use a gasoline dispenser nozzle, keep the nozzle in contact with the rim of the fuel tank or container opening at all times until fueling is complete.
- For best results, use only clean, fresh, unleaded gasoline with an octane rating of 87 or higher ((R+M)/2 rating method).

- Oxygenated fuel with up to 10% ethanol or 15% MTBE by volume is acceptable.
- **Do Not** use ethanol blends of gasoline (such as E15 or E85) with more than 10% ethanol by volume. Performance problems and/or engine damage may result which may not be covered under warranty.
- **Do Not** use gasoline containing methanol.
- **Do Not** store fuel either in the fuel tank or fuel containers over the winter unless a fuel stabilizer is used.
- **Do Not** add oil to gasoline.

Important: Do not use fuel additives other than a fuel stabilizer/conditioner. Do not use fuel stabilizers with an alcohol base such as ethanol, methanol, or isopropanol.

1. Clean around the fuel tank cap (Figure 8).

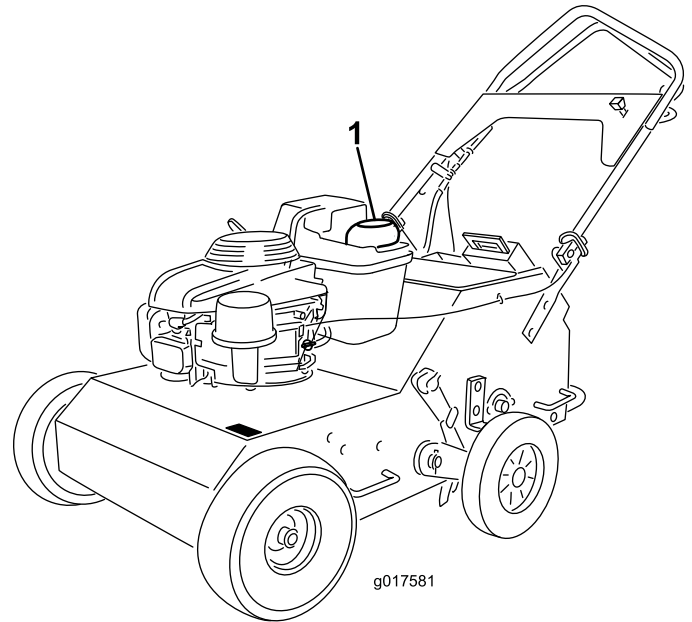

Figure 8

1. Fuel tank cap

2. Remove the cap from the tank.
3. Fill the fuel tank with unleaded gasoline to within 1/4 to 1/2 inch (6 to 13 mm) from the top of the tank. **Do not fill into the filler neck.**

Important: Do not fill the tank more than 1/4 inch (6 mm) from the top of the tank because the gasoline must have room to expand.

4. Install the fuel tank cap and wipe up any spilled gasoline.

Starting the Engine

1. Connect the wire to the spark plug.
2. Open the fuel valve by turn it in-line with the fuel hose (Figure 9).

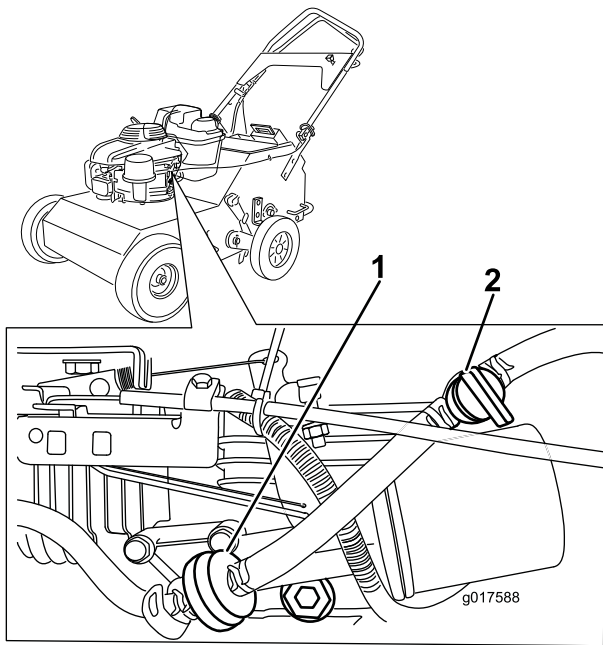

Figure 9

1. Fuel filter
2. Fuel valve—off position

3. Move the throttle control all the way forward to the Choke position (Figure 9).

Note: Do not use the choke when the engine is warm.

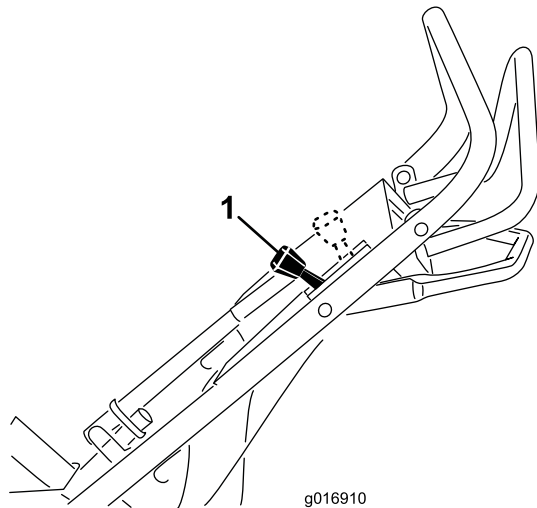

Figure 10

1. Throttle control

4. Pull the starter handle lightly until you feel resistance, then pull it sharply. Allow the rope to return to the handle slowly.
5. When the engine starts, move the throttle control to the Fast position.

Note: The throttle setting governs the maximum drive speed of the aerator.

Stopping the Engine

1. Release the traction control lever and allow it to return to neutral.
2. Move the throttle lever all the way rearward to stop the engine.

Driving the Machine

- To move forward, press the control lever forward (Figure 11). The further forward you push it, the faster the machine will travel.
- To move in reverse, pull the control lever rearward (Figure 11). The further forward you pull it, the faster the machine will travel.

▲ WARNING

The aerator tines are sharp and can puncture your feet or other body parts.

Use extreme care when moving in reverse so that you do not allow your feet to go close to the tines. Watch for and avoid obstacles you could trip over.

- To turn the machine, move slowly and press down on the handles; turn the machine in the desired direction then resume normal operation.
- To stop, release the control lever (Figure 11).

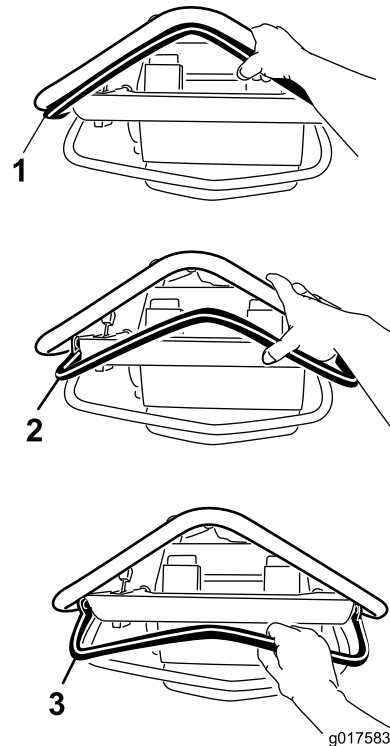

Figure 11

1. Forward
2. Neutral (Stop)
3. Reverse

Note: If your machine is moving too slowly and not properly aerating, see Adjusting the Machine Ground Speed (page 20)

Aerating

1. Drive the machine to the desired location and stop it.
2. Push the tine control lever down and forward to raise the rear wheels and engage the tines.

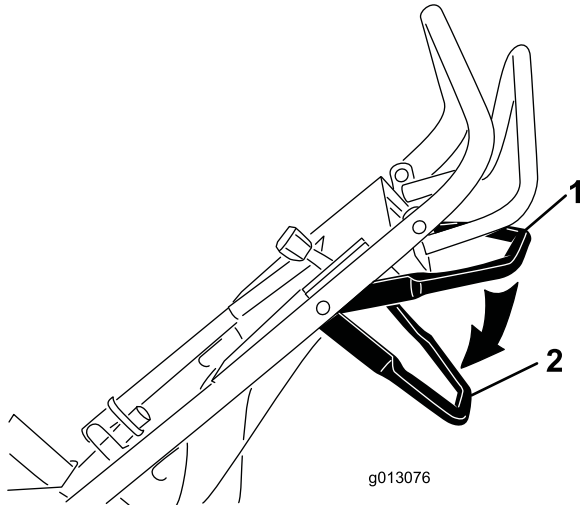

Figure 12

1. Tine control lever—disengaged
2. Tine control lever—engaged

3. Drive the machine to aerate the desired area.

Note: The machine will aerate in both forward and reverse.

4. When finished, stop the machine and pull the tine control lever rearward and up to lower the rear wheels and lift the tines out of the ground.

Important: Do not drive the machine across pavement or other hard surfaces without first raising the tines. Crossing hard surfaces with the tines lowered will damage the tines.

Adding Weight

To ensure that the tines penetrate fully into the soil, you can add weight to the back of the machine. The machine has three weight pockets that hold the weights (Figure 13). When placing weight, ensure that you have a balanced load; if using only one weight, place it in the center pocket and if using two, place them in the side pockets.

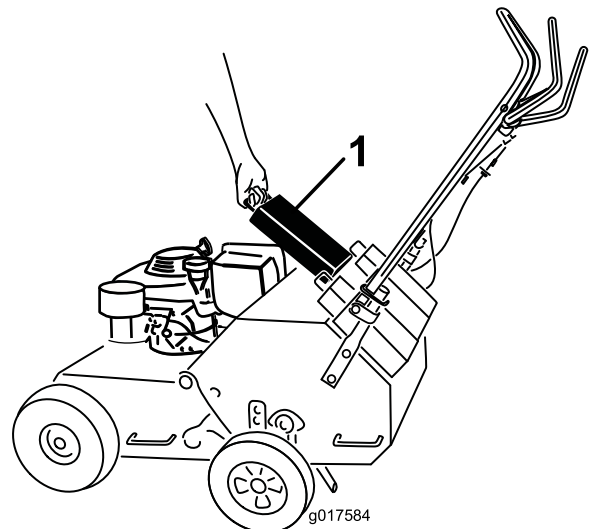

Figure 13

1. Weight

Adjusting the Coring Depth

A coring depth of 2-1/2 inches (6.35 cm) is recommended, but you can change the depth as follows:

1. Raise the tines, stop the machine, stop the engine, and disconnect the spark plug wire.
2. Loosen the nuts securing the wheel stop on the right side of the machine (Figure 14).

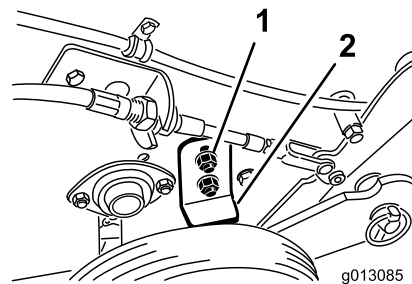

Figure 14

1. Nuts
2. Wheel stop

3. Raise the wheel stop to increase the coring depth and lower it to reduce the depth as required.
4. Tighten the nuts securely to lock the wheel stop in place.
5. Repeat steps 2 through 4 for the wheel stop on the left side of the machine. Set the wheel stops to the same height on each side.

Securing the Machine for Transport

When transporting the machine on a trailer, always use the following procedure:

Important: Do not operate or drive the machine on roadways.

1. Drive the machine onto that trailer, stop the machine, stop the engine, turn off the fuel valve, and disconnect the spark plug wire.

Important: If you do not turn off the fuel valve, the engine may flood during transport.

2. Secure the machine to the trailer with chains or straps using the tie-down/lift loops (Figure 5).

Operating Tips

- For best performance and maximum tine penetration, water the turf thoroughly the day before aerating.
- Clean the area of debris before using the machine.
- Mark and avoid shallow obstacles such as sprinkler heads and invisible fence wires.

Maintenance

Recommended Maintenance Schedule(s)

Maintenance Service Interval	Maintenance Procedure
After the first 8 hours	<ul style="list-style-type: none">• Change the engine oil.
After the first 10 hours	<ul style="list-style-type: none">• Check the tension of the drive chains.
After the first 25 hours	<ul style="list-style-type: none">• Check the tension of the hydrostatic drive belt.
Before each use or daily	<ul style="list-style-type: none">• Check the engine oil level.• Lubricate the pivot arms.• Check the tire pressure.• Check the condition of the coring tines and replace any that are damaged or excessively worn.• Check for loose fasteners.
Every 25 hours	<ul style="list-style-type: none">• Lubricate and check the drive chains.• Clean the foam pre-cleaner (more frequently in dusty conditions).
Every 50 hours	<ul style="list-style-type: none">• Change the engine oil.• Check the tension of the drive chains.• Check the tension of the hydrostatic drive belt.
Every 100 hours	<ul style="list-style-type: none">• Change the oil filter.• Inspect, clean, and adjust the spark plug; replace it if necessary.
Every 200 hours	<ul style="list-style-type: none">• Replace the spark plug.
Every 250 hours	<ul style="list-style-type: none">• Replace the fuel filter.
Every 300 hours	<ul style="list-style-type: none">• Replace the paper air filter (more frequently in dusty conditions).
Yearly or before storage	<ul style="list-style-type: none">• Touch up chipped paint

⚠ CAUTION

If you leave the spark pug wire connected, someone could accidently start the engine and seriously injure you or other bystanders.

Before performing any maintenance, park the unit on a level surface, stop the engine, and disconnect the spark plug wire. Set the wire aside so that it does not accidentally contact the spark plug.

Premaintenance Procedures

Accessing the Tines

The machine has a rear access panel that you can remove as illustrated in to access and maintain the tines.

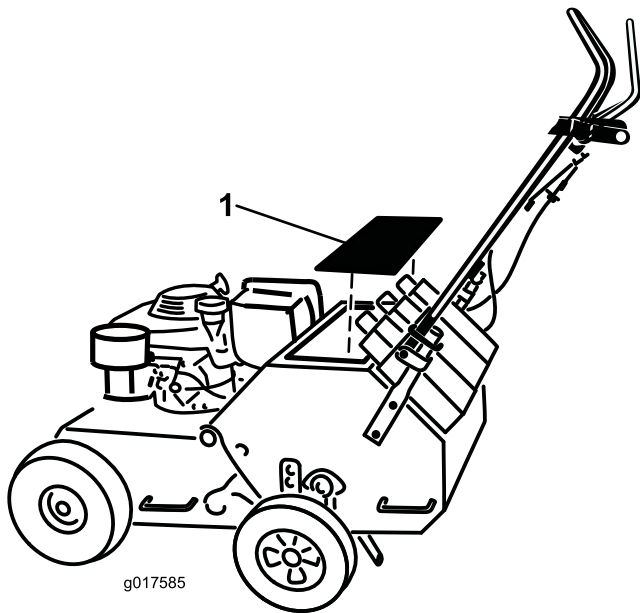

Figure 15

⚠ WARNING

Mechanical or hydraulic jacks may fail to support machine and cause a serious injury.

- Use jack stands when supporting machine.
- Do not use hydraulic jacks.

⚠ WARNING

If you operate the machine with the rear access panel removed, some one could be severely injured by contact with the moving tines or by flying debris.

Always securely install the rear access panel before operating the machine.

Tipping the Machine

If you need to work on the underside of the machine, you can tip it back until it is resting on the rear guard (Figure 16). Do not tip the machine forward or you will foul the air cleaner with gasoline. Secure the machine with a jack stand before working under it.

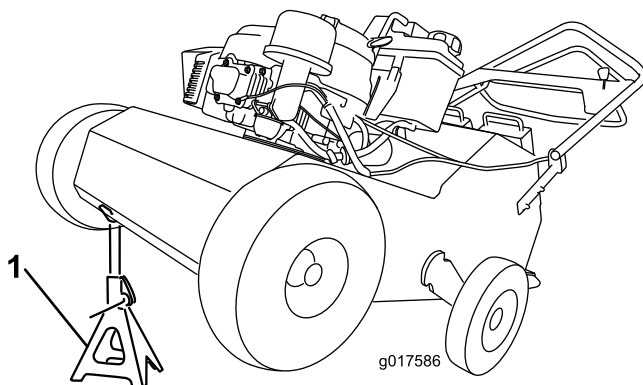

Figure 16

1. Jack stand

Lubrication

Greasing the Center Tines

Service Interval: Before each use or daily

1. Raise the tines, stop the machine, stop the engine, and disconnect the spark plug wire.
2. Remove the rear access panel; refer to Accessing the Tines (page 13)
3. Manually rotate the 2 center tine assemblies until you can see the grease fittings (Figure 17).

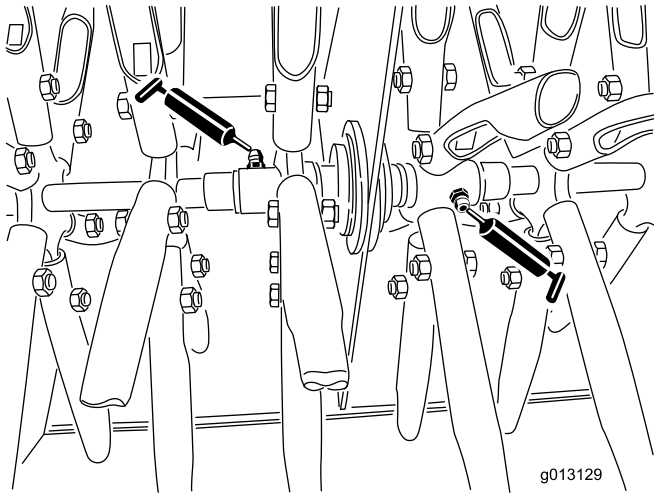

Figure 17

engine to flood and the air cleaner to be fouled with gasoline.

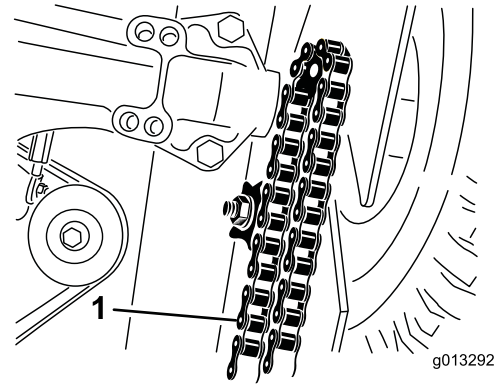

Figure 18

1. Chain (left side shown)

3. Apply a general purpose oil (10W30) onto the lower chain span while rotating the front wheel to expose un-oiled chain links until the whole chain is oiled.
4. Repeat step 3 for the other chain.
5. Wipe up any oil that spilled and lower the machine to the ground when finished.

4. Wipe the grease fittings with a clean rag.
5. Install a grease gun onto the fitting and gently apply 2 or 3 pumps of #2 multi-purpose lithium base grease.

Important: Excessive grease pressure may damage the seals.

Lubricating the Drive Chains

Service Interval: Every 25 hours

1. Raise the tines, stop the machine, stop the engine, and disconnect the spark plug wire.
2. Raise the front of the machine to gain access to the chains (Figure 18) and block it in place.

⚠ CAUTION

If you do not securely block the up the front of the machine, the machine could fall on you during service, injuring you.

Ensure that you place a jack-stand or block under the front of the machine to hold it up securely.

Important: Do not raise the rear of the machine. Raising the rear of the machine will cause the

Engine Maintenance

Servicing the Air Cleaner

Service Interval: Every 25 hours—Clean the foam pre-cleaner (more frequently in dusty conditions).

Every 300 hours—Replace the paper air filter (more frequently in dusty conditions).

Important: Do not operate the engine without the air filter assembly; extreme engine damage may occur.

1. Stop the engine and wait for all moving parts to stop.
2. Disconnect the wire from the spark plug.
3. Remove the cover and clean it thoroughly (Figure 19).

Note: Be careful to prevent dirt and debris from falling into the base.

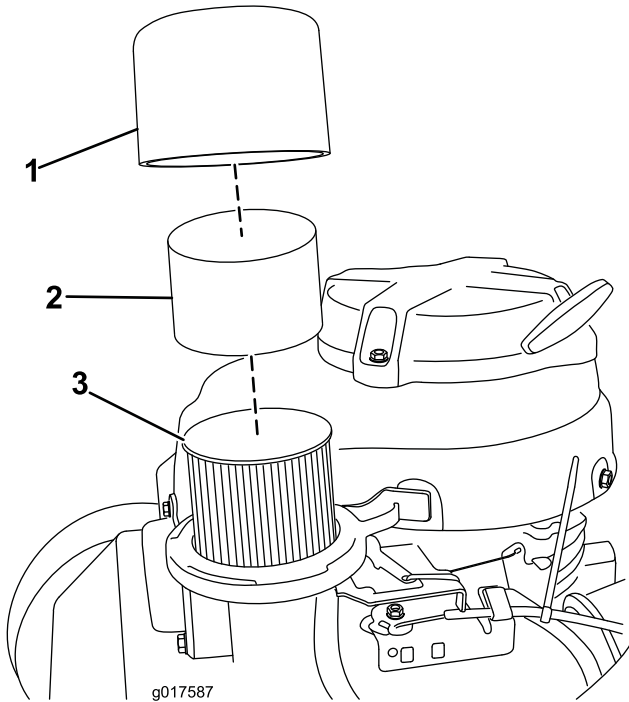

Figure 19

1. Cover
2. Foam pre-cleaner
3. Paper air filter

4. Remove the foam pre-cleaner and wash it with a mild detergent and water, then blot it dry (Figure 19).
5. Remove and inspect the paper air filter (Figure 19); discard it if it is excessively dirty.

Important: Do not try to clean a paper filter.

6. Wipe dirt from the base and the cover with a moist rag.

Note: Be careful to prevent dirt and debris from entering the air duct leading to the carburetor.

7. Install the foam pre-cleaner onto the paper air filter.
Note: Use a new paper air filter if you discarded the old one.
8. Install the air filter assembly and cover.

Changing the Engine Oil

Service Interval: After the first 8 hours

Every 50 hours

Oil Capacity	
With oil filter	29 ounces (0.85 L)
Without oil filter	22 ounces (0.65 L)£

1. Run the engine to warm the engine oil.

Note: Warm oil flows better and carries more contaminants.

⚠ WARNING

Oil may be hot after engine has been run, and contact with hot oil can cause severe personal injury.

Avoid contacting the hot engine oil when you drain it.

2. Stop the engine and wait for all moving parts to stop.
3. Disconnect the wire from the spark plug.
4. Place a drain pan on the ground to the right of the machine.
5. Remove the dipstick (Figure 20).

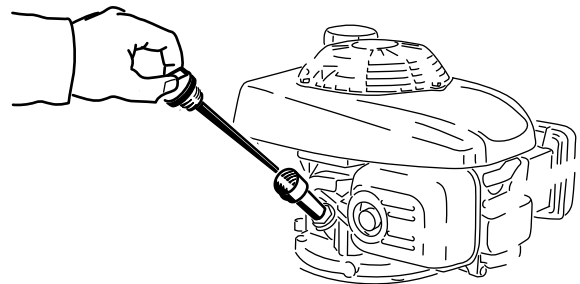

Figure 20

6. Remove the drain plug (Figure 21) and tip the machine so the oil flows to the pan.

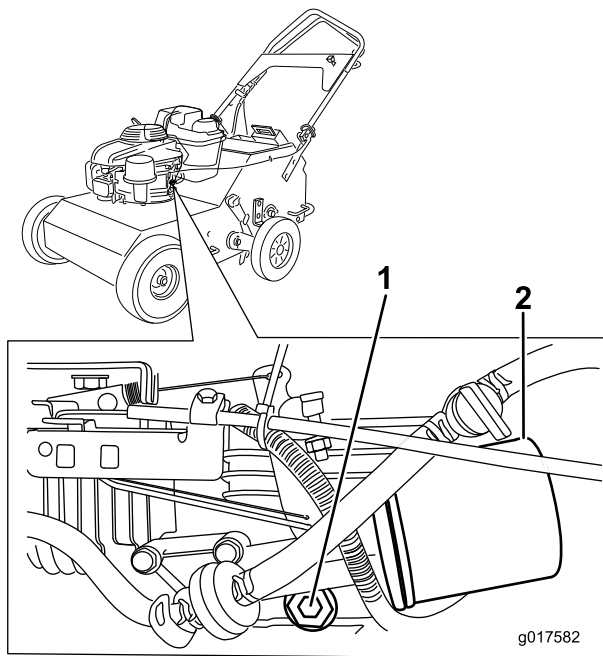

Figure 21

1. Oil drain plug
2. Oil filter

7. Tip the machine upright again, clean the oil from the frame with a rag and replace the drain plug.
8. Insert the dipstick into the filler neck and rotate the cap clockwise until it is tight.
9. **Slowly** pour oil into the oil fill tube, periodically checking the level with the dipstick, until the dipstick indicates that the engine is full. **Do not overfill.** (Max. fill: 20 oz. (0.55 l), type: SAE 30W detergent oil with an API service classification of SH, SJ, SL, or higher.)
Note: If you overfill the engine, pour some oil out of it.
10. Install the dipstick securely.
11. Recycle the used oil according to local codes.

Changing the Oil Filter

Service Interval: Every 100 hours

1. Drain the engine oil; refer to Changing the Engine Oil (page 16).
2. Place a rag under the oil filter (Figure 21) to catch any oil that may leak out as you remove the filter.
3. Remove the oil filter.
4. Use your finger to coat the gasket on the new filter with oil (Figure 22).

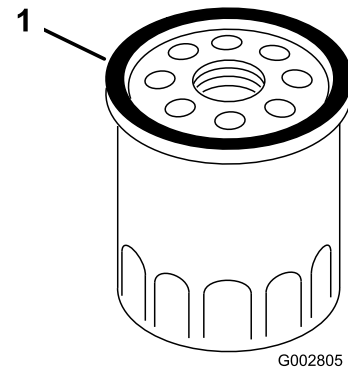

Figure 22

5. Install the new filter and hand tighten it 2/3 turn only.
6. Insert the dipstick into the filler neck and rotate the cap clockwise until it is tight.
7. **Slowly** pour oil into the oil fill tube, periodically checking the level with the dipstick, until the dipstick indicates that the engine is full. **Do not overfill.** (Max. fill: 20 oz. (0.55 l), type: SAE 30W detergent oil with an API service classification of SH, SJ, SL, or higher.)
Note: If you overfill the engine, pour some oil out of it.
8. Install the dipstick securely.
9. Connect the wire to the spark plug.
10. Run the engine for about 3 minutes.
11. Stop the engine, wait for all moving parts to stop, and check for oil leakage around the filter.
12. Check and add oil to compensate for the oil in the oil filter. **Do not overfill.**
13. Recycle the used oil filter according to local codes.

Servicing the Spark Plug

Service Interval: Every 100 hours—Inspect, clean, and adjust the spark plug; replace it if necessary.

Every 200 hours—Replace the spark plug.

Use an **NGK BPR6ES** spark plug or equivalent.

1. Stop the engine and wait for all moving parts to stop.
2. Disconnect the wire from the spark plug.
3. Clean around the spark plug.
4. Remove the spark plug from the cylinder head.

Important: Replace a cracked, fouled, or dirty spark plug. **Do not clean the electrodes because grit entering the cylinder can damage the engine.**

5. Set the gap on the plug to 0.030 inch (0.76 mm) (Figure 23).

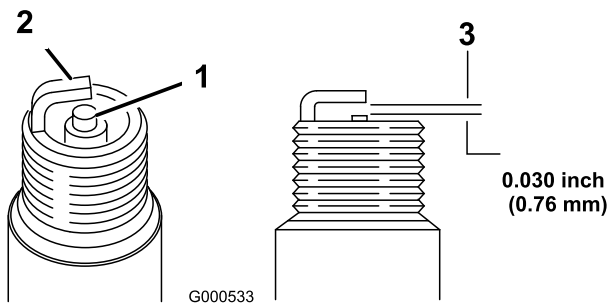

Figure 23

1. Center electrode insulator
2. Side electrode
3. Air gap (not to scale)

6. Carefully install the spark plug by hand (to avoid cross threading) until it is hand tight.
7. Tighten the spark plug an additional 1/2 turn if it is new; otherwise, tighten it an additional 1/8 to 1/4 turn.

Important: A loose spark plug can become very hot and can damage the engine; overtightening a spark plug may damage the threads in the cylinder head.

8. Connect the wire to the spark plug.

Fuel System Maintenance

Replacing the Fuel Filter

Service Interval: Every 250 hours

1. Stop the engine and wait for it to cool down.

Important: Drain gasoline from a cold engine only.

2. Disconnect the wire from the spark plug.
3. Close the fuel valve.
4. Clamp off the fuel line on either side of the fuel filter (Figure 24) to prevent fuel from leaking out when you remove the filter.

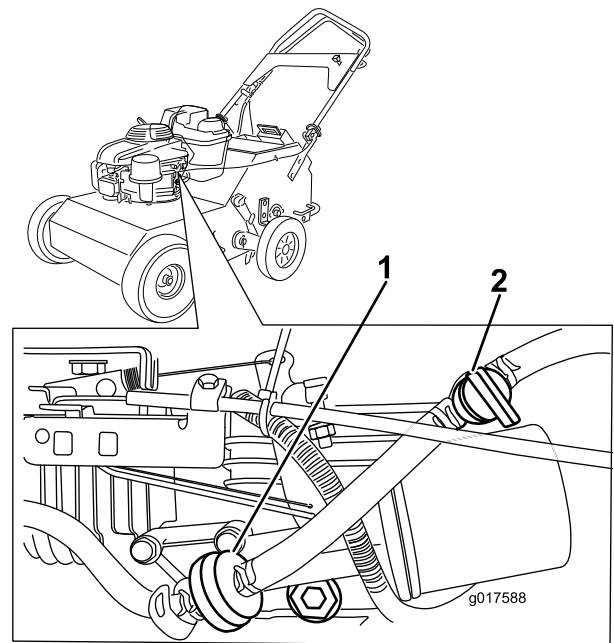

Figure 24

1. Fuel filter
2. Fuel valve

5. Squeeze the ends of the hose clamps together and slide them away from the filter (Figure 24).
6. Remove the filter from the fuel lines.
7. Install a new filter and move the hose clamps close to the filter (Figure 24).
8. Remove the clamps from the fuel lines.
9. Open the fuel shutoff valve.

Drive System Maintenance

Checking the Tire Pressure

Service Interval: Before each use or daily

Maintain the air pressure in the tires as specified. Check the tires when they are cold to get the most accurate reading.

Pressure: 46 psi (317 kPa)

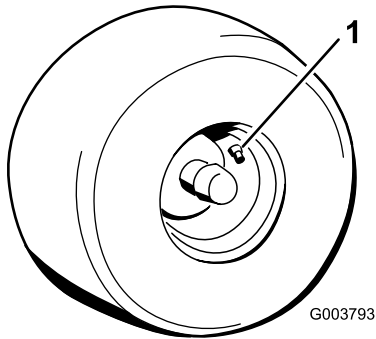

Figure 25

1. Valve stem

Checking the Tension of Aerator Drive Chains

Service Interval: After the first 10 hours

Every 50 hours

1. Raise the tines, stop the machine, stop the engine, and disconnect the spark plug wire.
2. Raise the front of the machine to gain access to the chains and block it in place.

CAUTION

If you do not securely block the up the front of the machine, the machine could fall on you during service, injuring you.

Ensure that you place a jackstand or block under the front of the machine to hold it up securely.

Important: Do not raise the rear of the machine. Raising the rear of the machine will casue the engine to flood and the air cleaner to be fouled with gasoline.

3. Pull down on each chain near the opening in the frame with 10 pounds (4.5 kg) of force (Figure 26). If a chain contacts the bottom of the opening in the frame, tighten it as follows:

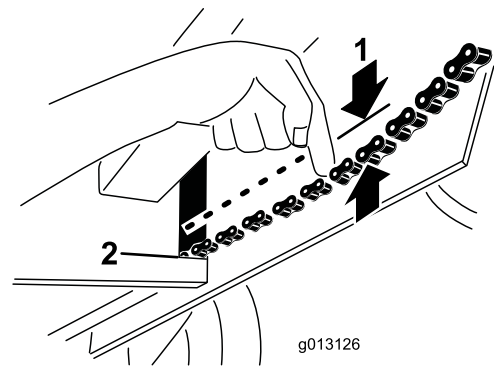

Figure 26

1. Flex in the chain
2. Bottom of the frame opening

- A. Loosen the nut securing the idler sprocket of the chain you are tensioning (Figure 27).

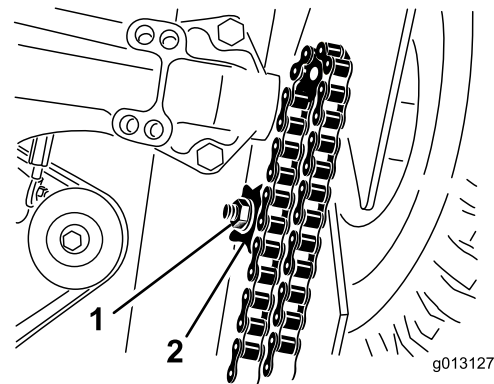

Figure 27

1. Idler sprocket

- B. Pull down on the idler sprocket until the slack is taken out of the chain and there is more than 1/4 inch (6 mm) of space between the chain and the bottom of the opening in the frame when you apply 10 pounds (4.5 kg) of force to the chain.
- C. Tighten the idler sprocket nut and torque it to 30 ft-lb (40.6 N-m).

Belt Maintenance

Checking the Hydrostatic Drive Belt

Service Interval: After the first 25 hours

Every 50 hours

1. Raise the tines, stop the machine, stop the engine, and disconnect the spark plug wire.
2. Raise the front of the machine to gain access to the pump drive belt and block it in place.

⚠ CAUTION

If you do not securely block the up the front of the machine, the machine could fall on you during service, injuring you.

Ensure that you place a jack stand or block under the front of the machine to hold it up securely.

Important: Do not raise the rear of the machine. Raising the rear of the machine will casue the engine to flood and the air cleaner to be fouled with gasoline.

3. Push on a span of the drive belt with 10 pounds (4.5 kg) of force (Figure 28). If the belt flexes more than 1/2 inch (1.3 cm), tighten it as follows:

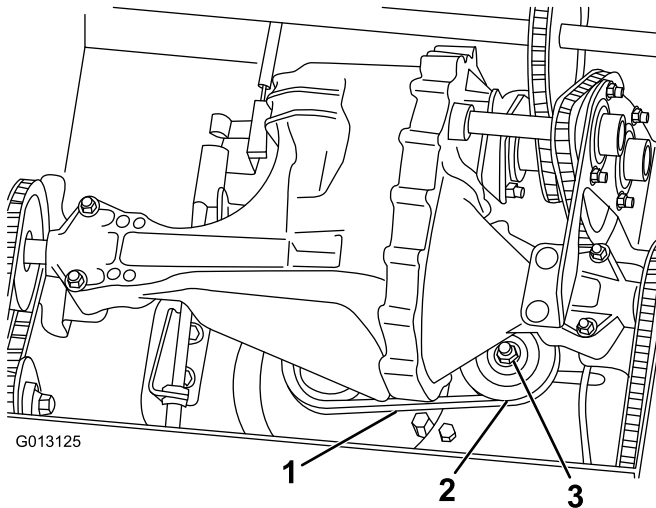

Figure 28

1. Pump drive belt
2. Idler pulley
3. Idler pulley nut

- A. Loosen the nut securing the idler pulley (Figure 28).
- B. Push the idler pulley to the left to tighten the belt .
- C. Tighten the idler pulley nut and torque it to 30 ft-lb (40.6 N-m).

Controls System Maintenance

Adjusting the Machine Ground Speed

1. Loosen the 2 bolts securing the cable attachment bracket and slide it as far as possible to the left then tighten the 2 bolts (Figure 29).

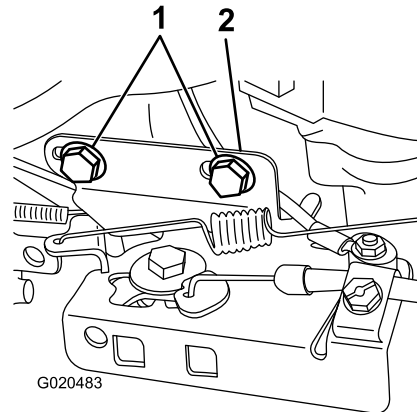

Figure 29

1. Bolts
2. Cable attachment bracket

2. Adjust the traction drive cable at the lower anchor by moving the nut to the end of the thread and tightening the jam nut (Figure 30).

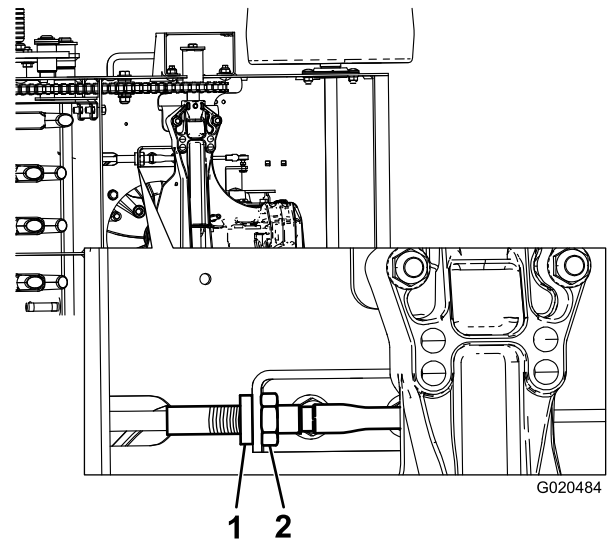

Figure 30

1. Nut
2. Jam nut

3. Adjust the traction drive cable at the handle as follows:
 - Loosen and remove the linkage adjustment from the bracket (Figure 31).
 - Move the lower nut to the end of the thread (Figure 31).

Note: Ensure that the bail will reach the handle after the transmission is engaged.

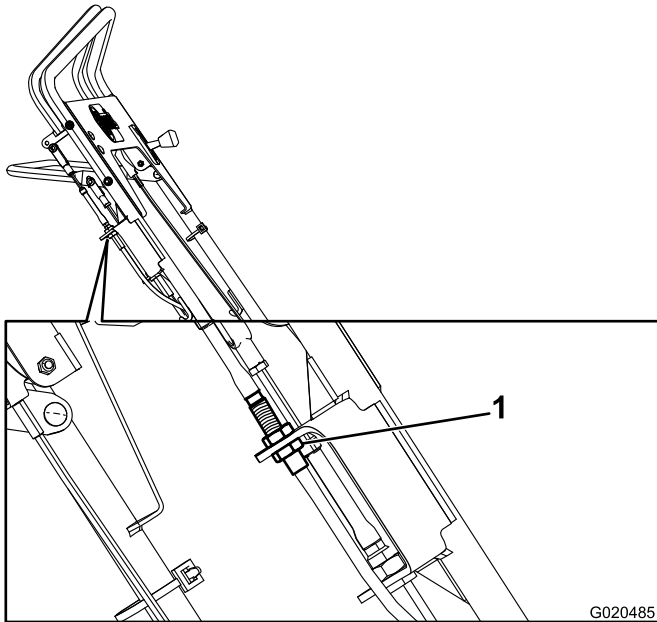

Figure 31

1. Lower nut

4. Adjust the reverse speed stop as follows:

- Loosen the 2 nuts on the reverse speed stop (Figure 32).
- Move the stop down to the midpoint or slightly past it and tighten the 2 nuts (Figure 32).

Note: The reverse speed should be around 3.2 km/h (2.0 MPH).

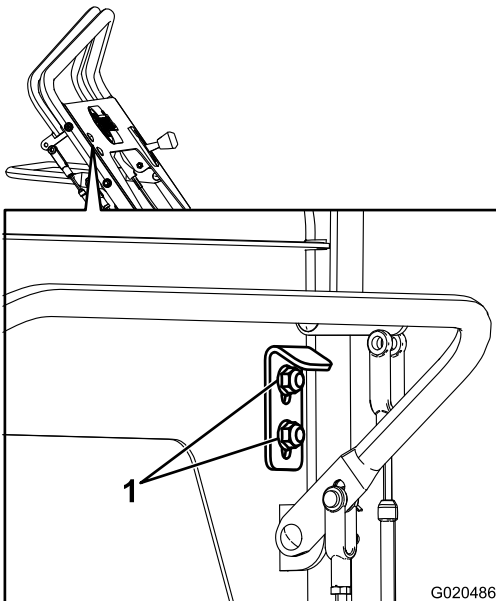

Figure 32

1. Nuts

Tine Maintenance

Checking/Replacing Tines

Service Interval: Before each use or daily

1. Raise the tines, stop the machine, stop the engine, and disconnect the spark plug wire.
2. Remove the rear access panel; refer to Accessing the Tines (page 13)
3. Manually rotate the tines on the shaft, inspecting them for wear or damage.
4. If any are damaged or broken, remove the nut and bolt securing the tine to the tine assembly (Figure 33).

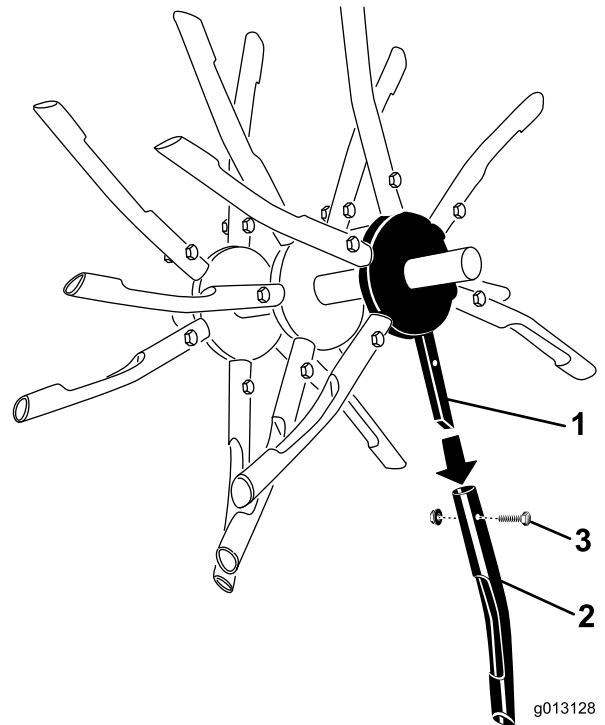

Figure 33

1. Tine assembly
2. Tine

3. Bolt and nut

5. Remove the tine and replace it with a new one. Ensure that the new tine is facing the same direction as the other tines on the assembly.
6. Secure the new tine with the bolt and nut you removed previously and torque them to 30 ft-lb (40.6 N-m).
7. When all tines have been inspected and replaced as needed, lower the machine to the ground and engage the hydrostatic drive.

Storage

1. Raise the tines, stop the machine, stop the engine, and disconnect the spark plug wire.
2. Remove dirt and grime from the entire machine.

Important: You can wash the machine with mild detergent and water. Do not pressure wash the machine. Avoid excessive use of water, especially near the engine and hydrostatic drive.

3. Service the air cleaner; refer to Servicing the Air Cleaner (page 16).
4. Grease the chains and floating tine assemblies; refer to Lubrication (page 15).
5. Change the engine oil; refer to Changing the Engine Oil (page 16).
6. Check and tighten all bolts, nuts, and screws. Repair or replace any part that is damaged.
7. Paint all scratched or bare metal surfaces. Paint is available from your Authorized Service Dealer.
8. Store the machine in a clean, dry garage or storage area.
9. Cover the machine to protect it and keep it clean.

Troubleshooting

Problem	Possible Cause	Corrective Action
Engine will not start.	<ol style="list-style-type: none"> 1. The throttle lever is in the Off position. 2. The spark plug is disconnected. 3. The fuel is turned off. 4. The traction lever is not in neutral. 	<ol style="list-style-type: none"> 1. Move the throttle lever to the Choke position. 2. Connect the spark plug. 3. Open the fuel valve. 4. Release the traction lever so it returns to neutral.
The machine vibrates abnormally.	<ol style="list-style-type: none"> 1. Loose bolts and/or broken parts. 	<ol style="list-style-type: none"> 1. Stop the machine and engine immediately. Replace any broken or missing parts.
The machine will not pull itself up hills.	<ol style="list-style-type: none"> 1. The drive belt to the hydrostatic pump is loose. 	<ol style="list-style-type: none"> 1. Check and tighten the pump drive belt.
The front wheels move but the tines do not.	<ol style="list-style-type: none"> 1. A chain or drive sprocket is broken. 	<ol style="list-style-type: none"> 1. Replace the broken chain or sprocket.
The engine smokes when starting.	<ol style="list-style-type: none"> 1. The engine was tipped forward. 	<ol style="list-style-type: none"> 1. Check the air cleaner and replace it if it is fouled. Always tip the machine back when servicing.
The engine is hard to start after transporting it.	<ol style="list-style-type: none"> 1. The fuel valve was not closed before transport and the engine is flooded. 	<ol style="list-style-type: none"> 1. Always close the fuel valve before transporting the machine.



Toro Compact Utility Equipment Warranty

A One-Year Limited Warranty

CUE Products

Conditions and Products Covered

The Toro® Company and its affiliate, Toro Warranty Company, pursuant to an agreement between them, jointly warrant your Toro Compact Utility Equipment ("Product") to be free from defects in materials or workmanship. The following time periods apply from the date of purchase:

Products	Warranty Period
Loaders, Trenchers, Stump Grinders, Chippers, Log Splitters and Attachments Kohler Engines	1 year or 1000 operating hours, whichever occurs first
All other Engines	3 years
	2 years

Where a warrantable condition exists, we will repair the Product at no cost to you including diagnosis, labor, and parts.

Instructions for Obtaining Warranty Service

If you think that your Toro Product contains a defect in materials or workmanship, follow this procedure:

1. Contact any Authorized Toro Compact Utility Equipment (CUE) Service Dealer to arrange service at their dealership. To locate a dealer convenient to you, access our website at www.Toro.com. You may also call our Toro Customer Care Department toll free at 888-865-5676 (U.S. customers) or 888-865-5691 (Canadian customers).
2. Bring the product and your proof of purchase (sales receipt) to the Service Dealer.
3. If for any reason you are dissatisfied with the Service Dealer's analysis or with the assistance provided, contact us at:

LCB Customer Care Department
Toro Warranty Company
8111 Lyndale Avenue South
Bloomington, MN 55420-1196
Toll Free: 888-865-5676 (U.S. customers)
Toll Free: 888-865-5691 (Canada customers)

Owner Responsibilities

You must maintain your Toro Product by following the maintenance procedures described in the *Operator's Manual*. Such routine maintenance, whether performed by a dealer or by you, is at your expense. Parts scheduled for replacement as required maintenance ("Maintenance Parts"), are warranted for the period of time up to the scheduled replacement time for that part. Failure to perform required maintenance and adjustments can be grounds for disallowing a warranty claim.

Items and Conditions Not Covered

Not all product failures or malfunctions that occur during the warranty period are defects in materials or workmanship. This express warranty does not cover the following:

- Product failures which result from the use of non-Toro replacement parts, or from installation and use of add-on, modified, or unapproved accessories
- Product failures which result from failure to perform required maintenance and/or adjustments
- Product failures which result from operating the Product in an abusive, negligent or reckless manner
- Parts subject to consumption through use unless found to be defective. Examples of parts which are consumed, or used up, during normal Product operation include, but are not limited to, teeth, tines, blades, spark plugs, tires, tracks, filters, chains, etc.
- Failures caused by outside influence. Items considered to be outside influence include, but are not limited to, weather, storage practices, contamination, use of unapproved coolants, lubricants, additives, or chemicals, etc.
- Normal "wear and tear" items. Normal "wear and tear" includes, but is not limited to, worn painted surfaces, scratched decals or windows, etc.
- Any component covered by a separate manufacturer's warranty
- Pickup and delivery charges

General Conditions

Repair by an Authorized Toro Compact Utility Equipment (CUE) Service Dealer is your sole remedy under this warranty.

Neither The Toro® Company nor Toro Warranty Company is liable for indirect, incidental or consequential damages in connection with the use of the Toro Products covered by this warranty, including any cost or expense of providing substitute equipment or service during reasonable periods of malfunction or non-use pending completion of repairs under this warranty. All implied warranties of merchantability and fitness for use are limited to the duration of this express warranty. Some states do not allow exclusions of incidental or consequential damages, or limitations on how long an implied warranty lasts, so the above exclusions and limitations may not apply to you.

This warranty gives you specific legal rights, and you may also have other rights which vary from state to state.

Except for the engine warranty coverage and the Emissions warranty referenced below, if applicable, there is no other express warranty. The Emissions Control System on your Product may be covered by a separate warranty meeting requirements established by the U.S. Environmental Protection Agency (EPA) or the California Air Resources Board (CARB). The hour limitations set forth above do not apply to the Emissions Control System Warranty. Refer to the California Emission Control Warranty Statement supplied with your Product or contained in the engine manufacturer's documentation for details.

Countries Other than the United States or Canada

Customers who have purchased Toro products exported from the United States or Canada should contact their Toro Distributor (Dealer) to obtain guarantee policies for your country, province, or state. If for any reason you are dissatisfied with your Distributor's service or have difficulty obtaining guarantee information, contact the Toro importer. If all other remedies fail, you may contact us at Toro Warranty Company.